

Technical data sheet

Product features



Electric range with cabinet

Model	SAP Code	00014774
--------------	-----------------	----------



- Device type: Electric unit
- Protection of controls: IP24
- Material: AISI 304 top plate and cladding

SAP Code	00014774	Net Weight [kg]	86.00
Net Width [mm]	1200	Power electric [kW]	15.600
Net Depth [mm]	730	Loading	400 V / 3N - 50 Hz
Net Height [mm]	900		

Technical data sheet

Technical drawing



Electric range with cabinet

Model

SAP Code

00014774

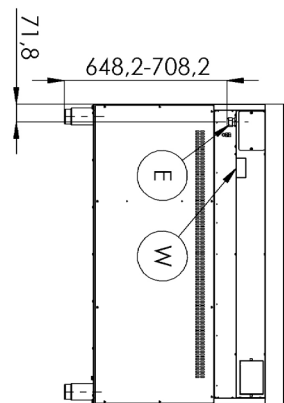
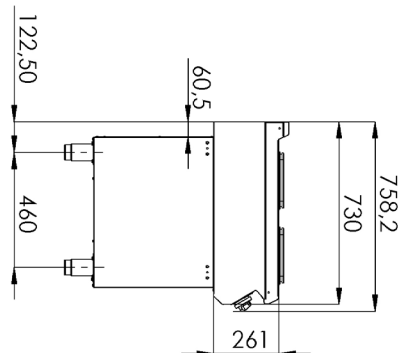
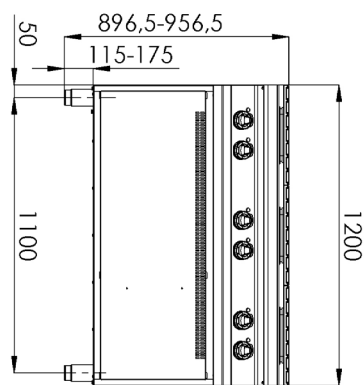

Technical data sheet

Technical parameters



Electric range with cabinet

Model

SAP Code

00014774

1. SAP Code:

00014774

2. Net Width [mm]:

1200

3. Net Depth [mm]:

730

4. Net Height [mm]:

900

5. Net Weight [kg]:

86.00

6. Gross Width [mm]:

1260

7. Gross depth [mm]:

820

8. Gross Height [mm]:

1080

9. Gross Weight [kg]:

103.00

10. Device type:

Electric unit

11. Construction type of device:

With substructure

12. Power electric [kW]:

15.600

13. Loading:

400 V / 3N - 50 Hz

14. Protection of controls:

IP24

15. Device color:

Stainless steel

16. Material:

AISI 304 top plate and cladding

17. Indicators:

operation

18. Worktop type:

Molded - comfortable cleaning maintenance

19. Worktop material:

AISI 304

20. Worktop Thickness [mm]:

1.50

21. Maximum device temperature [°C]:

400

22. Minimum device temperature [°C]:

50

23. Service accessibility:

Trough the frontal panel

24. Adjustable feet:

Yes

25. Number of burners/hot plates:

6

26. Type of electric cooking zones:

Squared